

SEPAK

INDUSTRIES PTY LTD
www.sepak.com.au



Sanitary Ball Valves



Applications

The butterfly type ball valve is applied to pipeline and equipment controls. It is widely used in brewing industries



Design and features

- Low maintenance
- Portable and compact
- Small torque moment
- Drainable
- Gasket complies with FDA 177.2600
- Hand lever can be installed on the side of the valve body, no matter of the flow direction
- Valve body can be replaced in any connection and the length will not change





INDUSTRIES PTY LTD

www.sepak.com.au



Materials

- Part contacted with media: AISI304/316L
- Gasket: EPDM(standard)
- Seal: PTFE
- Inner side polish: Ra0.8μm
- Out side polish: CNC lathe machining

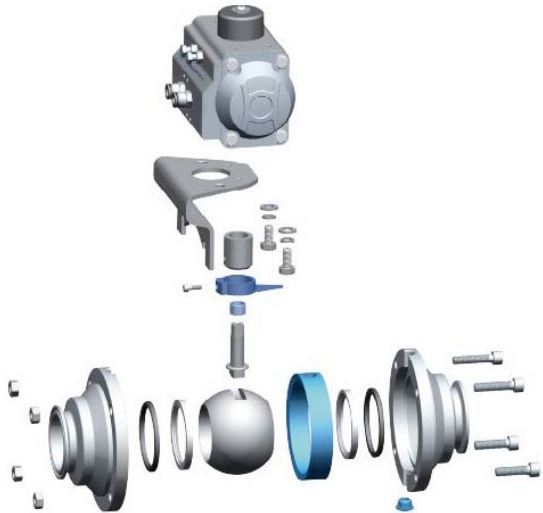

Options

- Connection ends: thread, clamp, weld, DIN, SMS, IDF, RJT, FIL
- Gasket: BNR, VITON(FPM), Silicone FDA 177.2600
- Manual drive: Sensor, multi position handle lever, pull handle lever
- Pneumatic drive: Aluminium electric/ pneumatic actuator
- Stainless steel electric/ pneumatic actuator
- Intelligent C top controls: AS-I connection. Electronic connection



Technical specification

- Max temperature: 121°C (EPDM)
- Pressure: 10 Bar

Operating torque(N.m.)

操作扭矩 (N.m) (干燥测试) Dry test	DN10–DN20	DN25	DN32	DN40	DN50	2.5"	DN65	DN80	DN100
	1/2"–3/4"	1"	1 1/4"	1 1/2"	2"	25	30	3"	4"
	8	8"	10	12	17			40	70

SEPAK

INDUSTRIES PTY LTD

www.sepak.com.au

Butterfly-type ball valve

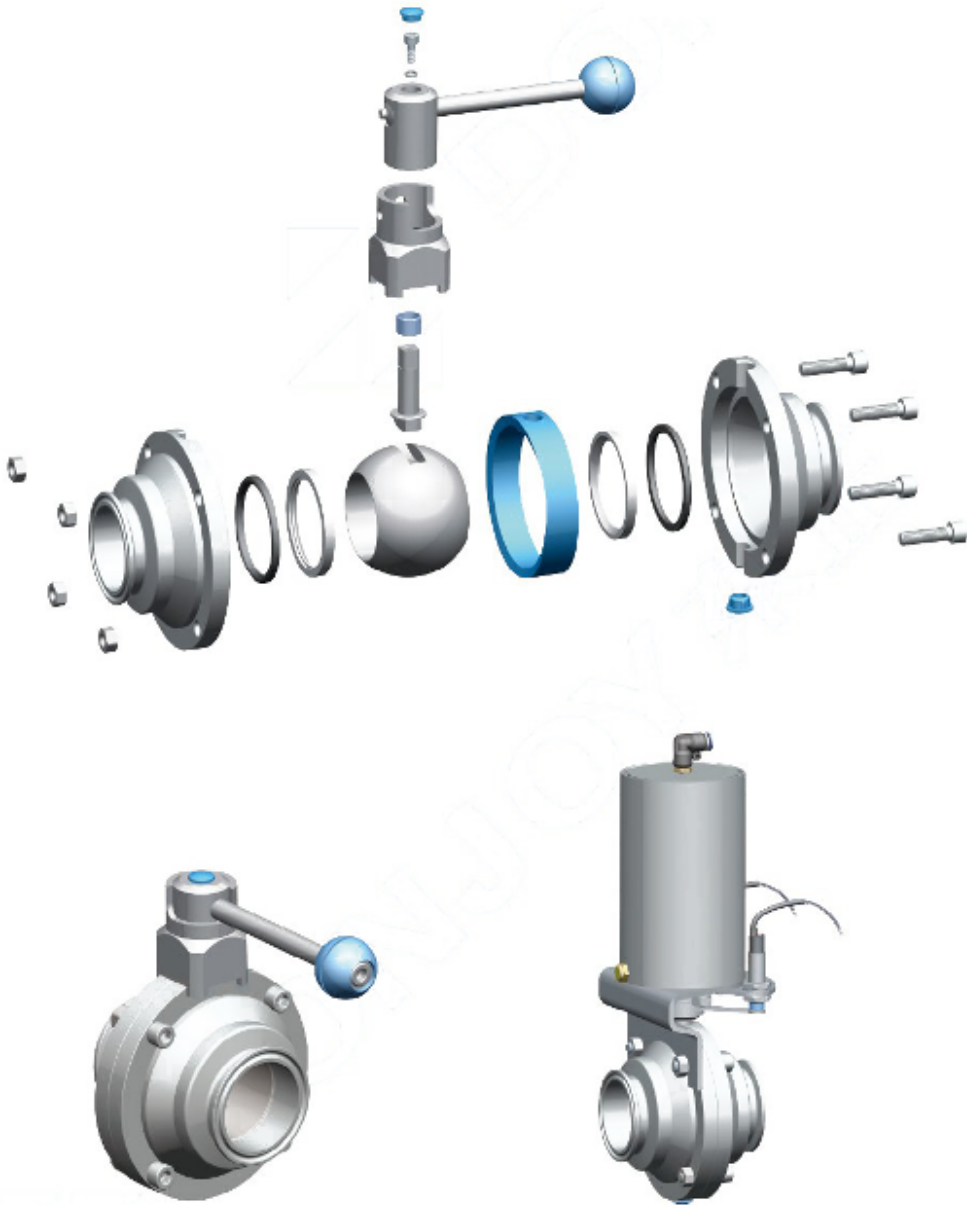



INDUSTRIES PTY LTD

www.sepak.com.au

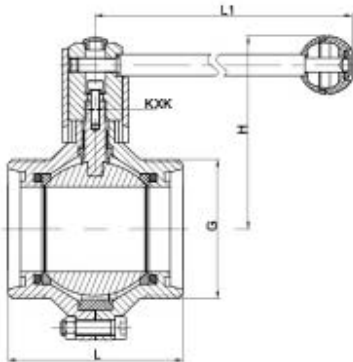

No.20201 Threaded butterfly-type ball valve(DIN)

SIZE	G	L	L1	H	KxK
DN15	Rd33.5x1/8	72	126	86	8x8
DN20	Rd43.5x1/8	72	126	86	8x8
DN25	Rd51.5x1/8	72	126	90	8x8
DN32	Rd57.5x1/8	80	126	92	8x8
DN40	Rd64.5x1/8	84	133	104	10x10
DN50	Rd77.5x1/8	98	144	113	10x10
DN65	Rd94.5x1/8	120	160	131	11x11
DN80	Rd109.3x1/4	140	220	144	11x11
DN100	Rd129.3x1/4	164	284	161	14x14

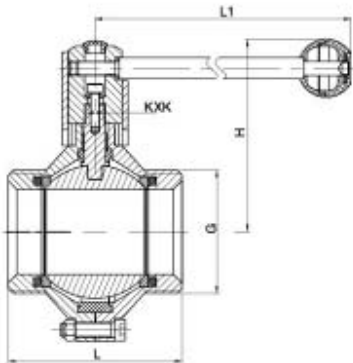

No.20235 Threaded butterfly-type ball valve(SA)

SIZE	D	L	L1	H	KxK
1"	37.1x1/8 Acme	72	126	90	8x8
1 _{1/2} "	45.9x1/8 Acme	80	126	92	8x8
1 _{1/2} "	50.6x1/8 Acme	84	133	104	10x10
2"	64.1x1/8 Acme	98	144	113	10x10
2 _{1/2} "	77.6x1/8 Acme	116	160	128	11x11
3"	91.1x1/8 Acme	132	220	138	11x11
4"	119.2x1/8 Acme	164	284	161	14x14

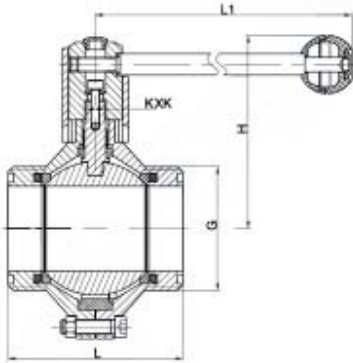

No.20202 Threaded butterfly-type ball valve(SMS)

SIZE	D	L	L1	H	KxK
3/4"	Rd35.5x1/8	72	126	86	8x8
1"	Rd39.5x1/8	72	126	90	8x8
1 _{1/2} "	Rd47.5x1/8	80	126	92	8x8
1 _{1/2} "	Rd59.5x1/8	84	133	104	10x10
2"	Rd69.5x1/8	98	144	113	10x10
2 _{1/2} "	Rd84.5x1/8	116	160	128	11x11
3"	Rd97.5x1/8	132	220	138	11x11
3 _{1/2} "	Rd104.3x1/8	140	220	144	11x11
4"小	Rd124.3x1/4	164	284	161	14x14
4"大	Rd131.3x1/8	164	284	161	14x14



INDUSTRIES PTY LTD

www.sepak.com.au

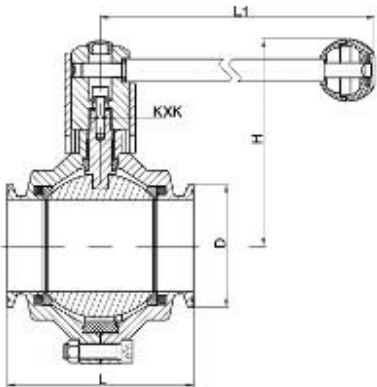

No.20213 Clamped butterfly-type ball valve(DIN)

SIZE	D	L	L1	H	t	KxK
DN15	34	72	126	86	1.5	8x8
DN20	34	72	126	86	1.5	8x8
DN25	50.5	72	126	90	1.5	8x8
DN32	50.5	80	126	92	1.5	8x8
DN40	50.5	84	133	104	1.5	10x10
DN50	64	98	144	113	1.5	10x10
DN65	91	120	160	131	2.0	11x11
DN80	106	140	220	144	2.0	11x11
DN100	119	164	284	161	2.0	14x14

No.20214 卡箍式蝶式球阀(3A、SMS、ISO、IDF、DS)
Clamped butterfly-type ball valve(3A,SMS,ISO,IDF,DS)

SIZE	D	L	L1	H	KxK
3/4"	25.4	72	126	86	8x8
1"	50.5	72	126	90	8x8
1 _{1/2} "	50.5	80	126	92	8x8
1 _{1/2} " _{ver}	50.5	84	133	104	10x10
2"	64	98	144	113	10x10
2 _{1/2} "	77.5	116	160	129	11x11
3"	91	132	220	139	11x11
3 _{1/2} "	106	140	220	144	11x11
4"	119	164	284	161	14x14

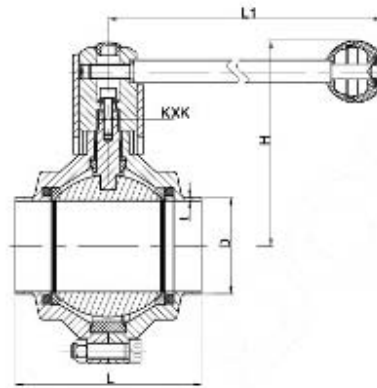

No.20209 Welded butterfly-type ball valve(DIN)

SIZE	D		L	L1	H	t	KxK
	1	2					
DN15	18	19	72	126	86	1.5	8x8
DN20	22	23	72	126	86	1.5	8x8
DN25	28	29	72	126	90	1.5	8x8
DN32	34	35	80	126	92	1.5	8x8
DN40	40	41	84	133	104	1.5	10x10
DN50	52	53	98	144	113	1.5	10x10
DN65	70	-	120	160	131	2.0	11x11
DN80	85	-	140	220	144	2.0	11x11
DN100	104	-	164	284	161	2.0	14x14

No.20210 Welded butterfly-type ball valve(3A,SMS,ISO,IDF,DS)

SIZE	D	L	L1	H	t	KxK
3/4"	19	72	126	86	1.5	8x8
1"	25.4	72	126	90	1.5	8x8
1 _{1/2} "	31.8	80	126	92	1.5	8x8
1 _{1/2} " _{ver}	38	84	133	104	1.5	10x10
2"	50.8	98	144	113	1.5	10x10
2 _{1/2} "	63.5	116	160	128	2.0	11x11
3"	76.2	132	220	138	2.0	11x11
3 _{1/2} "	89	140	220	144	2.0	11x11
4"	101.6	164	284	161	2.0	14x14

SEPAK

INDUSTRIES PTY LTD

www.sepak.com.au

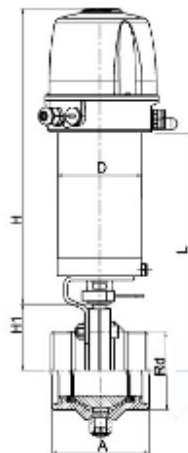

No.12020101 Pneumatic threaded butterfly-type ball valve(DIN)

Size	D	A	H	H1	L	Rd
DN15	86.3	72	297.5	42	214.5	RD94x1/8
DN20	86.3	72	297.5	42	214.5	RD44x1/8
DN25	86.3	72	297.5	46	218.5	RD52x1/8
DN32	86.3	80	297.5	48	220.5	RD58x1/8
DN40	86.3	84	297.5	56	228.5	RD65x1/8
DN50	86.3	98	297.5	65	234.5	RD78x1/8
DN65	114	120	380	80	324	RD94.5x1/8
DN80	114	140	380	93	337	RD109.3x1/4

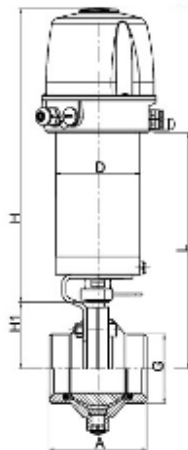

No.12023501 Pneumatic threaded butterfly-type ball valve(3A)

Size	D	A	H	H1	L	G
1"	86.3	72	297.5	46	218.5	37.1x1/8Acme
1 ^{1/4} "	86.3	80	297.5	48	220.5	45.9x1/8Acme
1 ^{1/2} "	86.3	84	297.5	56	228.5	50.6x1/8Acme
2"	86.3	98	297.5	65	234.5	64.1x1/8Acme
2.5"	114	116	380	77	321	77.6x1/8Acme
3.0"	114	132	380	87	331	91.1x1/8Acme

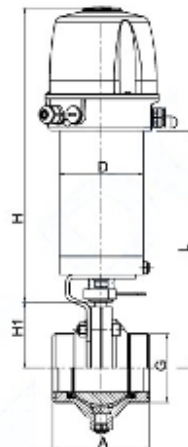

No.12020201 Pneumatic threaded butterfly-type ball valveSMS

Size	D	A	H	H1	L	G
φ 19	86.3	72	297.5	42	214.5	RD96x1/8
φ 25	86.3	72	297.5	46	218.5	RD40x1/8
φ 32	86.3	80	297.5	48	220.5	RD48x1/8
φ 38	86.3	84	297.5	56	228.5	RD60x1/8
φ 51	86.3	98	297.5	65	234.5	RD70x1/8
2.5"	114	116	380	77	321	RD84.5x1/8
3.0"	114	132	380	87	331	RD97.5x1/8



INDUSTRIES PTY LTD

www.sepak.com.au

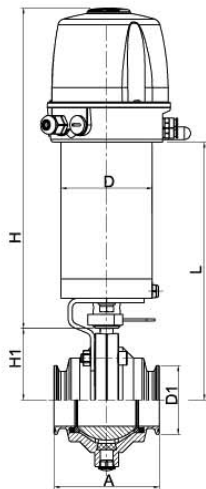

No.12021301 Pneumatic clamped butterfly-type ball valve(DIN)

Size	D	A	H	H1	L	D1
DN15	86.3	72	297.5	42	214.5	34
DN20	86.3	72	297.5	42	214.5	34
DN25	86.3	72	297.5	46	218.5	50.5
DN32	86.3	80	297.5	48	220.5	50.5
DN40	86.3	84	297.5	56	228.5	50.5
DN50	86.3	98	297.5	65	234.5	64
DN65	114	120	380	80	324	91
DN80	114	140	380	93	337	106

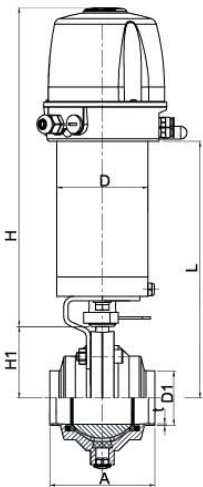

No.12021401 Pneumatic clamped butterfly-type ball valve (3A,SMS,ISO,IDF,DS)

Size	D	A	H	H1	L	G
3/4"	86.3	72	297.5	42	214.5	25.4
1"	86.3	72	297.5	46	218.5	50.5
1 1/4"	86.3	80	297.5	48	220.5	50.5
1 1/2"	86.3	84	297.5	56	228.5	50.5
2"	86.3	98	297.5	65	234.5	64
2.5"	114	116	380	77	321	77.5
3.0	114	132	380	87	331	91

No.12020901 Pneumatic welded butterfly-type ball valve(DIN)

Size	A	H	H1	D	L	t	D1	
							1	2
DN15	72	297.5	42	86.3	214.5	1.5	18	19
DN20	72	297.5	42	86.3	214.5	1.5	22	23
DN25	72	297.5	46	86.3	218.5	1.5	28	29
DN32	80	297.5	48	86.3	220.5	1.5	34	35
DN40	84	297.5	56	86.3	228.5	1.5	40	41
DN50	98	297.5	65	86.3	234.5	1.5	52	53
DN65	120	380	77	114	324	2.0	70	-
DN80	140	380	87	114	337	2.0	85	-

No.12021001 Pneumatic welded butterfly-type ball valve(3A,SMS,ISO,IDF,DS)

Size	A	H	H1	D	L
3/4"	72	297.5	42	86.3	214.5
1"	72	297.5	46	86.3	218.5
1 1/4"	80	297.5	48	86.3	220.5
1 1/2"	84	297.5	56	86.3	228.5
2"	98	297.5	65	86.3	234.5
2.5"	116	380	77	114	321
3.0"	132	380	87	114	331



INDUSTRIES PTY LTD

www.sepak.com.au

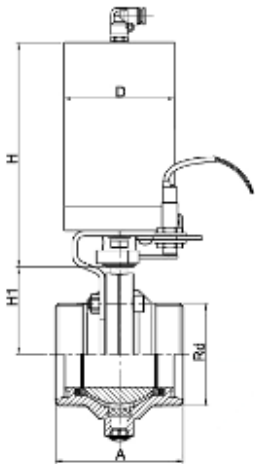

No. 12020102 Pneumatic threaded butterfly-type ball valve(DIN)

Size	A	H	H1	D	Rd
DN15	72	172.5	42	86.3	RD34x1/8
DN20	72	172.5	42	86.3	RD44x1/8
DN25	72	172.5	46	86.3	RD52x1/8
DN32	80	172.5	48	86.3	RD56x1/8
DN40	84	172.5	56	86.3	RD65x1/8
DN50	98	172.5	65	86.3	RD76x1/8

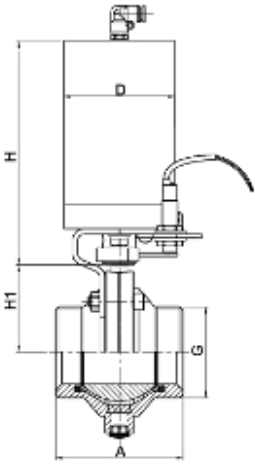

No. 12023502 Pneumatic threaded butterfly-type ball valve(3A)

Size	A	H	H1	D	G
1"	72	172.5	46	86.3	37.1x1/8Acme
1 1/4"	80	172.5	48	86.3	45.9x1/8Acme
1 1/2"	84	172.5	56	86.3	50.6x1/8Acme
2"	98	172.5	65	86.3	64.1x1/8Acme

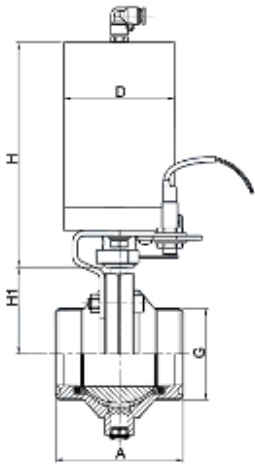

No. 12020202 Pneumatic threaded butterfly-type ball valve(SMS)

Size	A	H	H1	D	G
φ 19	72	172.5	42	86.3	RD36x1/8
φ 25	72	172.5	46	86.3	RD40x1/8
φ 32	80	172.5	48	86.3	RD48x1/8
φ 38	84	172.5	56	86.3	RD60x1/8
φ 51	98	172.5	65	86.3	RD70x1/8



INDUSTRIES PTY LTD

www.sepak.com.au

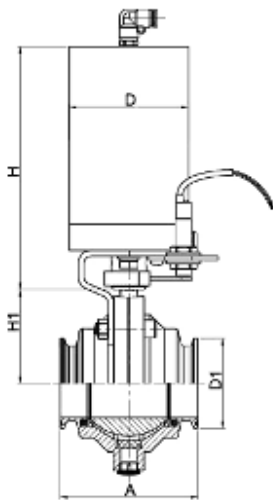

No.12021302 Pneumatic clamped butterfly-type ball valve(DIN)

Size	A	H	H1	D	D1
DN15	72	172.5	42	86.3	34
DN20	72	172.5	42	86.3	34
DN25	72	172.5	46	86.3	50.5
DN32	80	172.5	48	86.3	50.5
DN40	84	172.5	56	86.3	50.5
DN50	98	172.5	65	86.3	64

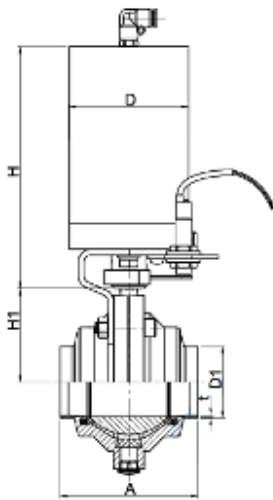

No.12020902 Pneumatic welded butterfly-type ball valve(DIN)

Size	A	H	H1	t	D	D1	
						1	2
DN15	72	172.5	42	1.5	86.3	18	19
DN20	72	172.5	42	1.5	86.3	22	23
DN25	72	172.5	46	1.5	86.3	28	29
DN32	80	172.5	48	1.5	86.3	34	35
DN40	84	172.5	56	1.5	86.3	40	41
DN50	98	172.5	65	1.5	86.3	52	53

No.12021002 Pneumatic welded butterfly-type ball valve (3A,SMS,ISO,IDF,DS)

Size	A	H	H1	D	D1
3/4"	72	172.5	42	86.3	19
1"	72	172.5	46	86.3	25.4
1 1/4"	80	172.5	48	86.3	31.8
1 1/2"	84	172.5	56	86.3	38.1
2"	98	172.5	65	86.3	50.8

SEPAK

INDUSTRIES PTY LTD

www.sepak.com.au

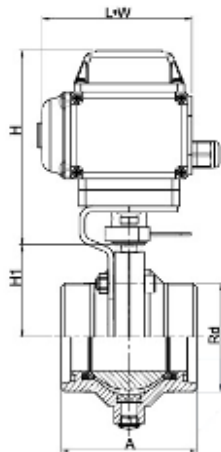

No.12020103 Electric threaded butterfly-type ball valve(DIN)

Size	A	H	H1	Rd	LxW
DN15	72	141	42	RD34x1/8	162x115
DN20	72	141	42	RD44x1/8	162x115
DN25	72	141	46	RD52x1/8	162x115
DN32	80	141	48	RD58x1/8	162x115
DN40	84	141	56	RD65x1/8	162x115
DN50	98	153	65	RD78x1/8	208x122
DN65	120	153	80	RD95x1/8	208x122
DN80	140	200	93	RD110x1/4	258x148
DN100	164	200	107.5	RD130x1/4	258x148

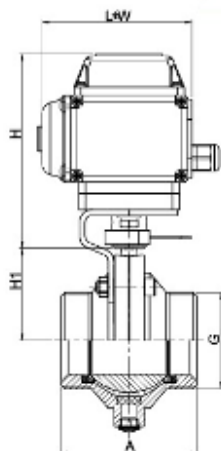

No.12023503 Electric threaded butterfly-type ball valve(3A)

Size	A	H	H1	G	LxW
1"	72	141	46	37.1X1/8Acme	162x115
1 1/2"	80	141	48	45.9X1/8Acme	162x115
1 1/2"	84	141	56	50.6X1/8Acme	162x115
2"	98	153	65	64.1X1/8Acme	208x122
2 1/2"	120	153	80	77.6X1/8Acme	208x122
3"	140	200	93	91.1X1/8Acme	258x148
4"	164	200	107.5	119.2X1/8Acme	258x148

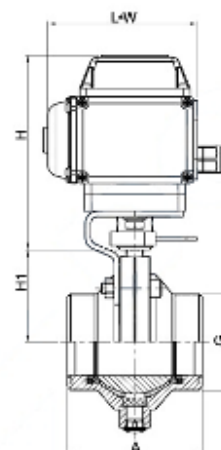

No.12020203 Electric threaded butterfly-type ball valve(SMS)

Size	A	H	H1	G	LxW
3/4"	72	141	42	Rd35.5X1/8	162x115
1"	72	141	46	Rd39.5X1/8	162x115
1 1/2"	80	141	48	Rd47.5X1/8	162x115
1 1/2"	84	141	56	Rd59.5X1/8	162x115
2"	98	153	65	Rd69.5X1/8	208x122
2 1/2"	116	153	77	Rd84.5X1/8	208x122
3"	132	200	87	Rd97.3X1/8	258x148
3 1/2"	140	200	93	Rd104.3X1/8	258x148
4" 小	164	200	107.5	Rd124.3X1/4	258x148
4" 大	164	200	107.5	Rd131.3X1/8	258x148

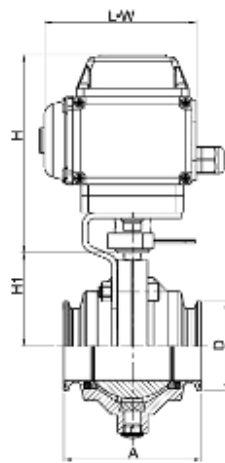

No. 12021303 Electric clamped butterfly-type ball valve(DIN)

Size	A	H	H1	D	LxW
DN15	72	141	42	34	162x115
DN20	72	141	46	34	162x115
DN25	80	141	48	50.5	162x115
DN32	84	141	56	50.5	162x115
DN40	98	141	65	50.5	162x115
DN50	116	153	77	64	208x122
DN65	132	153	87	91	208x122
DN80	140	200	93	106	258x148
DN100	164	200	107.5	119	258x148

No. 12021403 Electric clamped butterfly-type ball valve(3A,3MS,3O,3CF,DS)

Size	A	H	H1	D	LxW
3/4"	72	141	42	25.5	162x115
1"	72	141	46	50.5	162x115
1 _{1/4} "	80	141	48	50.5	162x115
1 _{1/2} "	84	141	56	50.5	162x115
2"	98	153	65	64	208x122
2 _{1/2} "	116	153	77	77.5	208x122
3"	132	200	87	91	258x148
3 _{1/2} "	140	200	93	106	258x148
4"	164	200	107.5	119	258x148

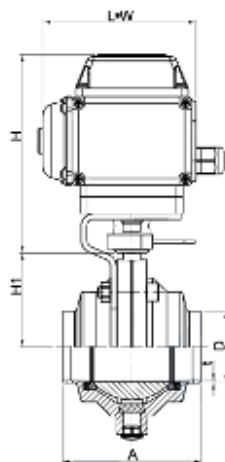

No. 12020903 Electric welded butterfly-type ball valve(DIN)

Size	A	H	H1	t	LxW	D1	
						1	2
DN15	72	141	42	1.5	162x115	18	19
DN20	72	141	42	1.5	162x115	22	23
DN25	72	141	46	1.5	162x115	28	29
DN32	80	141	48	1.5	162x115	34	35
DN40	84	141	56	1.5	162x115	40	41
DN50	98	153	65	1.5	208x122	52	53
DN65	120	153	80	2.0	208x122	70	-
SN80	140	200	93	2.0	258x148	85	-
SN100	164	200	107.5	2.0	258x148	104	-

No. 12021003 Electric welded butterfly-type ball valve(3A,3MS,3O,3CF,DS)

Size	A	H	H1	D	D1
3/4"	72	141	42	19	162x115
1"	72	141	46	25.4	162x115
1 _{1/4} "	80	141	48	31.8	162x115
1 _{1/2} "	84	141	56	38.1	162x115
2"	98	153	65	50.8	208x122
2 _{1/2} "	116	153	77	63.5	208x122
3"	132	200	87	76.2	258x148
3 _{1/2} "	140	200	93	89	258x148
4"	164	200	107.5	101.6	258x148

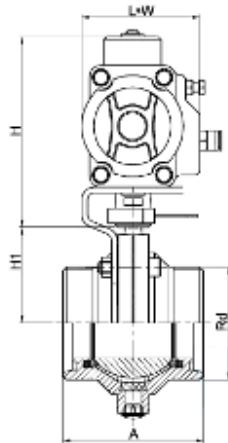

No.12020104 Pneumatic threaded butterfly-type ball valve(DIN)

Size	A	H	H1	Rd	LxW
DN15	72	117	42	RD34x1/8	140.5x70.5
DN20	72	117	42	RD44x1/8	140.5x70.5
DN25	80	117	42	RD52x1/8	140.5x70.5
DN32	84	133	46	RD58x1/8	158.5x83
DN40	98	150	48	RD65x1/8	210.5x94.5
DN50	116	150	56	RD78x1/8	210.5x94.5
DN65	132	187	65	RD95x1/8	247.5x106.3
SN80	140	199	72.5	RD110x1/4	268.5x123
SN100	164	227	82.5	RD130x1/4	315x141

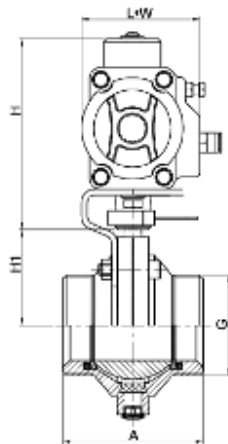

No.12023504 Pneumatic threaded butterfly-type ball valve(3A)

Size	A	H	H1	G	LxW
1"	72	117	46	37.1x1/8Acme	140.5X70.5
1 _{1/2} "	80	133	48	45.9x1/8Acme	158.5X83
1 _{1/2} "	84	150	56	50.6x1/8Acme	210.5X94.5
2"	98	150	65	64.1x1/8Acme	210.5X94.5
2 _{1/2} "	116	187	77	77.6x1/8Acme	247.5X106.3
3"	132	199	87	91.1x1/8Acme	268.5X123
4"	164	227	107.5	119.2x1/8Acme	315X141

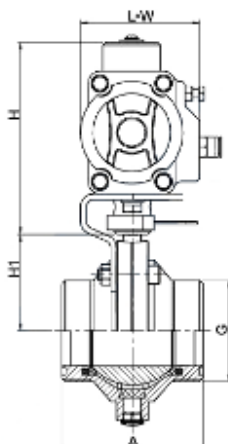

No.12020204 Pneumatic threaded butterfly-type ball valve(SMS)

Size	A	H	H1	G	LxW
3/4"	72	117	42	Rd35.5X1/8	140.5x70.5
1"	72	117	46	Rd39.5X1/8	140.5x70.5
1 _{1/2} "	80	133	48	Rd47.5X1/8	158.5x83
1 _{1/2} "	84	150	56	Rd59.5X1/8	210.5x94.5
2"	98	150	65	Rd69.5X1/8	210.5x94.5
2 _{1/2} "	116	187	77	Rd84.5X1/8	247.5x106.3
3"	132	199	87	Rd97.3X1/8	268.5x123
3 _{1/2} "	140	199	93	Rd104.3X1/8	268.5x123
4" 小	164	227	107.5	Rd124.3X1/4	315x141
4" 大	164	227	107.5	Rd131.3X1/8	315x141

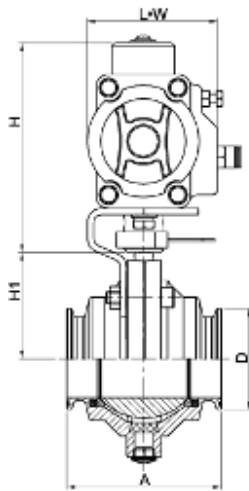

No. 12021304 Pneumatic clamped butterfly-type ball valve(DIN)

Size	A	H	H1	D	LxW
DN15	72	117	42	34	140.5x70.5
DN20	72	117	42	34	140.5x70.5
DN25	80	117	46	50.5	140.5x70.5
DN32	84	133	48	50.5	158.5x83
DN40	98	150	56	50.5	210.5x94.5
DN50	116	150	65	64	210.5x94.5
DN65	132	187	80	91	247.5x106.3
SN80	140	199	93	106	268.5x123
SN100	164	227	107.5	119	315x141

No. 12021404 Pneumatic clamped butterfly-type ball valve(3A, SMS, ISO, IDF, DS)

Size	A	H	H1	D	LxW
3/4"	72	117	42	25.4	140.5x70.5
1"	72	117	46	50.5	140.5x70.5
1 _{1/2} "	80	133	48	50.5	158.5x83
1 _{1/2} "	84	150	56	50.5	210.5x94.5
2"	98	150	65	64	210.5x94.5
2 _{1/2} "	116	187	77	77.5	247.5x106.3
3"	132	199	87	91	268.5x123
3 _{1/2} "	140	199	93	106	268.5x123
4"	164	227	107.5	119	315x141

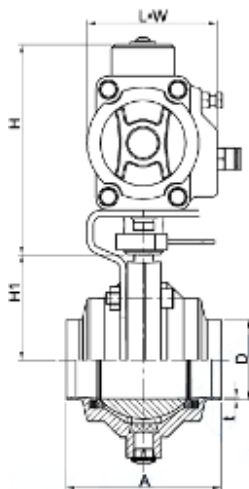

No. 12020904 Pneumatic welded butterfly-type ball valve(DIN)

Size	A	H	H1	t	LxW	D1	
						1	2
DN15	72	117	42	1.5	140.5x70.5	18	19
DN20	72	117	42	1.5	140.5x70.5	22	23
DN25	72	117	46	1.5	140.5x70.5	28	29
DN32	80	133	48	1.5	158.5x83	34	35
DN40	84	150	56	1.5	210.5x94.5	40	41
DN50	98	150	65	1.5	210.5x94.5	52	53
DN65	120	187	80	2.0	247.5x106.3	70	-
SN80	140	199	93	2.0	268.5x123	85	-
SN100	164	227	107.5	2.0	315x141	104	-

No. 12021004 Pneumatic welded butterfly-type ball valve(3A, SMS, ISO, IDF, DS)

Size	A	H	H1	D	LxW
3/4"	72	117	42	19	140.5x70.5
1"	72	117	46	25.4	140.5x70.5
1 _{1/2} "	80	133	48	31.8	158.5x83
1 _{1/2} "	84	150	56	38.1	210.5x94.5
2"	98	150	65	50.8	210.5x94.5
2 _{1/2} "	116	187	77	63.5	247.5x106.3
3"	132	199	87	76.2	268.5x123
3 _{1/2} "	140	199	93	89	268.5x123
4"	164	227	107.5	101.6	315x141

Non-Resort ball Valve



Applications

Overall valve body design prevents the medium from retaining in the valve after flowing through the body. This kind of ball valve is applied to pharmacy



Design and features

- Combined valve bodies, clamped connections
- Easily disassemble without special tools
- Operating torque is small
- Gasket complies with FDA 177.2600
- Connection ends: clamps, weld, thread, DIN, SMS, ISO, IDF, BPE, RJT
- Valve body can be replaced in any connections without changing the length

Clamped non-retention ball valve

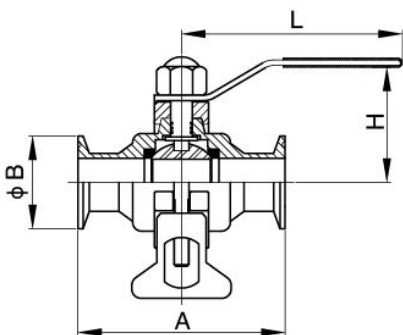

No.20225					DIN	No.20226					SMS、ISO、3A
Size	A	B	H	L		Size	A	B	H	L	
DN15	90.0	34.0	65.0	105.0		3/4"	19	90.0	25.4	65.0	105.0
DN20	100.0	34.0	65.0	105.0		1"	25	110.0	50.5	70.0	105.0
DN25	110.0	50.5	70.0	105.0		1 1/4"	32	120.0	50.5	80.0	130.0
DN32	120.0	50.5	80.0	130.0		1 1/2"	38	140.0	50.5	80.0	150.0
DN40	140.0	50.5	80.0	150.0		2"	51	164.0	64.0	85.0	160.0
DN50	164.0	64.0	85.0	160.0		2 1/4"	57	170.0	77.5	110.0	180.0
DN65	180.0	91.0	110.0	180.0		2 1/2"	63	180.0	77.5	110.0	180.0

Direct way ball valve

Applications

- Suitable for beverage, brewing, oil refinery, cosmetic, chemical industries

Design and features

- Free of maintenance
- Compact and portable
- Small operating torque
- Gasket complies with PTFE FDA 177.2600
- Hand lever can be installed on the side of the valve body, no matter of the flow direction
- Connection ends: thread, clamp, weld, flange, DIN, SMS, RJT, FIL
- Suitable for electric and pneumatic actuators
- Material: parts in contact with media: AISI 304/316L, Other parts: AISI304

Options

- Type of valves: One way ball valve, Three-piece ball valve, and Three-way ball valve
- Type of cores: T type, L type, direct type
- With cleaning and drainage port





INDUSTRIES PTY LTD

www.sepak.com.au

DirAect way ball valve

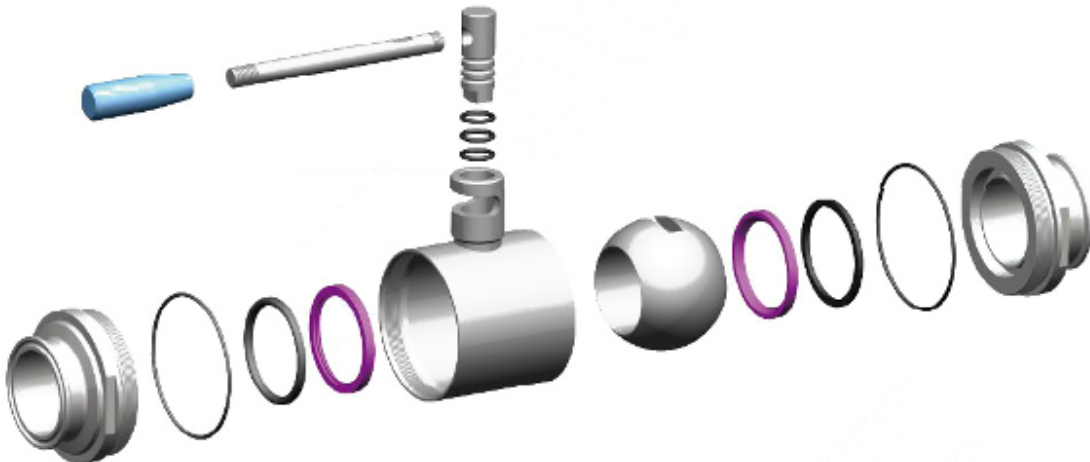

Three-piece ball valve

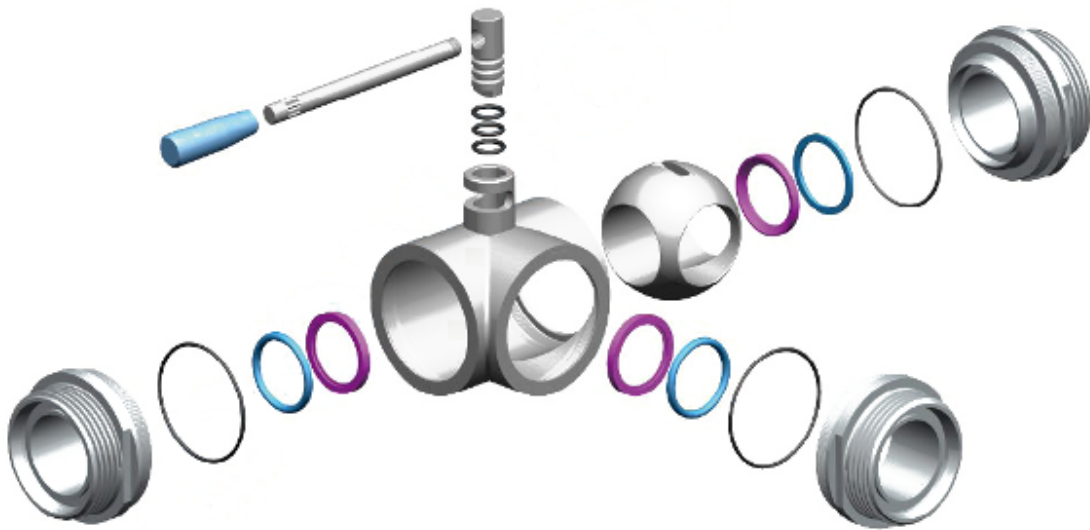



INDUSTRIES PTY LTD

www.sepak.com.au

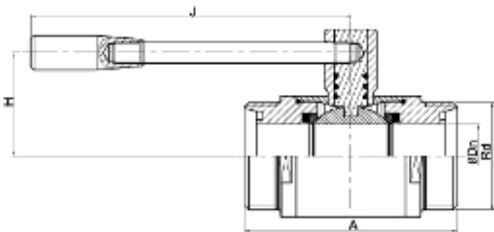

No.20260 Direct way threaded ball valve (DIN)

Size	Rd	Dn	A	H	J	N.W
DN10	Rd28 × 1/8"	10	95	42	124	820
DN15	Rd34 × 1/8"	15	95	42	124	850
DN20	Rd44 × 1/8"	19	95	42	124	945
DN25	Rd52 × 1/8"	25	100	48	146	1300
DN32	Rd58 × 1/8"	31	108	50	146	1740
DN40	Rd65 × 1/8"	37	123	60	185	2180
DN50	Rd78 × 1/8"	49	136	68	185	2960
DN65	Rd95 × 1/8"	66	161	85	243	5100
DN80	Rd110 × 1/4"	81	180	96	243	7390
DN100	Rd130 × 1/4"	100	204	114	273	11120

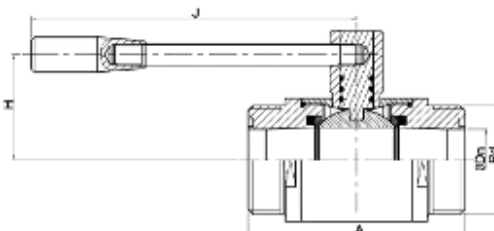

No.20261 Direct way threaded ball valve (SMS)

Size	Rd	Dn	A	H	J	N.W
1/2"	Rd36 × 1/8"	9.7	95	42	124	945
3/4"	Rd36 × 1/8"	16	95	42	124	900
1"	Rd40 × 1/8"	22.4	100	48	146	1200
1 ₁₆ "	Rd48 × 1/8"	28.8	108	60	185	1600
1 ₁₂ "	Rd60 × 1/8"	35.1	123	60	185	2340
2"	Rd70 × 1/8"	47.8	136	68	185	2860
2 ₁₂ "	Rd85 × 1/8"	59.5	150	80	205	4560
3"	Rd98 × 1/8"	72.2	172	90	243	6200
4"	Rd125 × 1/4"	97.6	204	114	273	11290

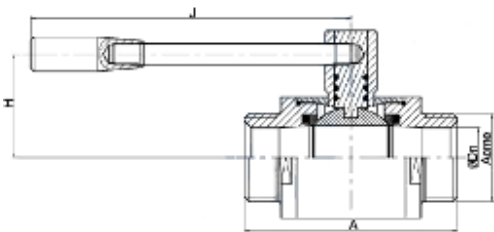

No.20262 Direct way threaded ball valve (3A)

Size	Acme	Dn	A	H	J
1/2"	37.1 × 1/8"	9.4	100	48	146
3/4"	37.1 × 1/8"	15.8	100	48	146
1"	37.1 × 1/8"	22.1	100	48	146
1 ₁₆ "	45.9 × 1/8"	28.8	108	60	185
1 ₁₂ "	50.6 × 1/8"	34.8	123	60	185
2"	64.1 × 1/8"	47.5	136	68	185
2 ₁₂ "	77.6 × 1/8"	60.2	150	80	205
3"	91.1 × 1/8"	72.9	172	90	243
4"	119.2 × 1/8"	97.4	204	114	273



INDUSTRIES PTY LTD

www.sepak.com.au



INDUSTRIES PTY LTD

www.sepak.com.au

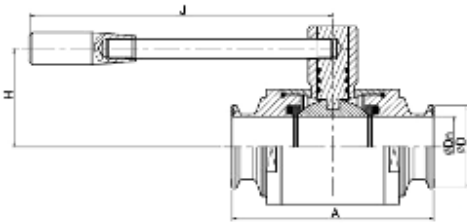

No.20263 Direct way clamped ball valve(DIN)

Size	D	Dn	A	H	J	N.W
DN10	34	10	95	42	124	835
DN15	34	15	95	42	124	795
DN20	34	19	95	42	124	760
DN25	50.5	25	100	48	146	1220
DN32	50.5	31	108	50	146	1535
DN40	50.5	37	123	60	185	2375
DN50	64	49	136	68	185	2645
DN65	91	66	161	85	243	4840
DN80	106	81	180	96	243	7090
DN100	119	100	204	114	273	10680

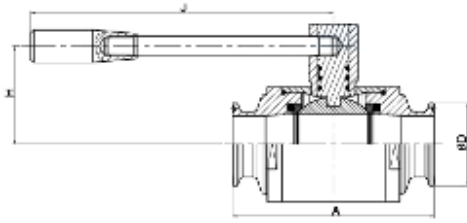

No.20264 Direct way clamped ball valve(ISO IDF SMS 3A DS)

Size	D	A	H	J	N.W
1/2"	25.4	95	42	124	810
3/4"	25.4	95	42	124	780
1"	50.5	100	48	146	1265
1 1/4"	50.5	108	60	185	1520
1 1/2"	50.5	123	60	185	2000
2"	64	136	68	185	2685
2 1/2"	77.5	150	80	205	4115
3"	91	172	90	243	5625
4"	119	204	114	273	10890

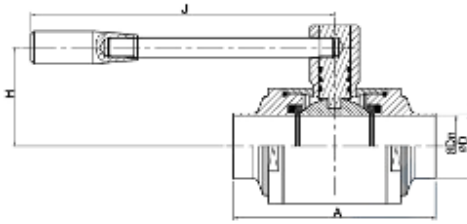

No.20265 Direct way welded ball valve(DIN)

Size	D	Dn	A	H	J
DN10	13	10	95	42	124
DN15	18	15	95	42	124
DN20	22	19	95	42	124
DN25	28	25	100	48	146
DN32	34	31	108	50	146
DN40	40	37	123	60	185
DN50	52	49	136	68	185
DN65	70	66	161	85	243
DN80	85	81	180	96	243
DN100	104	100	204	114	273

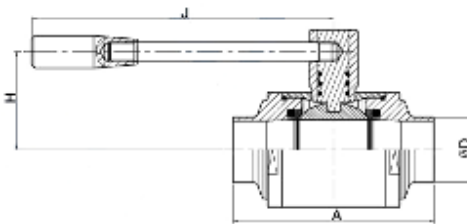

No.20266 Direct way welded ball valve(ISO IDF SMS 3A DS)

Size	D	A	H	J
1/2"	12.7	95	42	124
3/4"	19.1	95	42	124
1"	25.4	100	48	146
1 1/4"	31.8	108	60	185
1 1/2"	38.1	123	60	185
2"	50.8	136	68	185
2 1/2"	63.5	150	80	205
3"	76.2	172	90	243
4"	101.6	204	114	273



INDUSTRIES PTY LTD

www.sepak.com.au

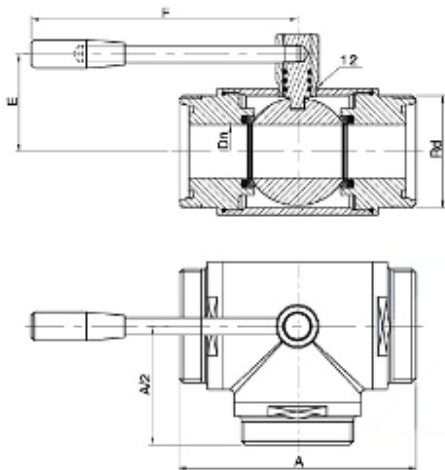

No.20267 Three-way threaded ball valve(DIN)

SIZE	Dn	Rd	A	E	F
DN25	25	Rd58x1/8"	140	50	146
DN32	31	Rd65x1/8"	156	64	185
DN40	37	Rd78x1/8"	172	68	185
DN50	49	Rd95x1/8"	182	95	243
DN65	66	Rd110x1/4"	196	104	243
DN80	81	Rd130x1/4"	256	122	273
DN100	100	Rd160x1/4"	286	173	273

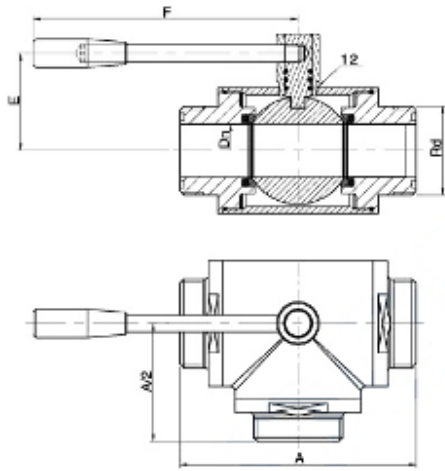
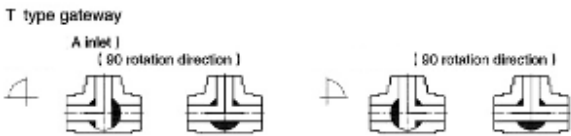

No.20268 Three-way threaded ball valve(SMS)

SIZE	Dn	Rd	A	E	F
1"	22.4	Rd40x1/8"	140	64	185
1 1/8"	28.8	Rd48x1/8"	156	64	185
1 1/2"	35.1	Rd60x1/8"	165	68	185
2"	47.8	Rd70x1/8"	182	73	205
2 1/2"	59.5	Rd85x1/8"	196	95	243
3"	72.2	Rd98x1/8"	225	104	243
4"	97.6	Rd125x1/4"	286	173	273





INDUSTRIES PTY LTD

www.sepak.com.au

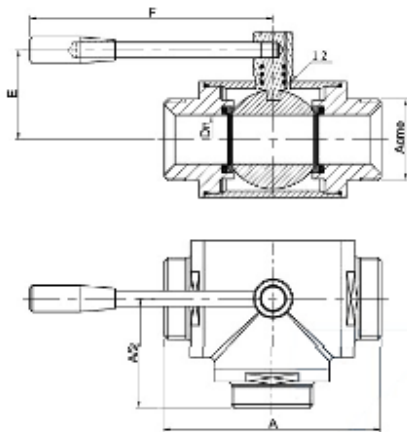

No.20269 Three-way threaded ball valve (3A)

SIZE	Acme	A	Dn	E	F
1"	37.1x1/8"	140	22.1	64	185
1 _{1/2} "	45.9x1/8"	156	28.8	64	185
1 _{3/4} "	53.6x1/8"	165	34.8	68	185
2"	64.1x1/8"	182	47.5	73	205
2 _{1/2} "	77.6x1/8"	196	60.2	85	243
3"	91.1x1/8"	225	72.9	104	243
4"	119.2x1/8"	286	97.4	173	273

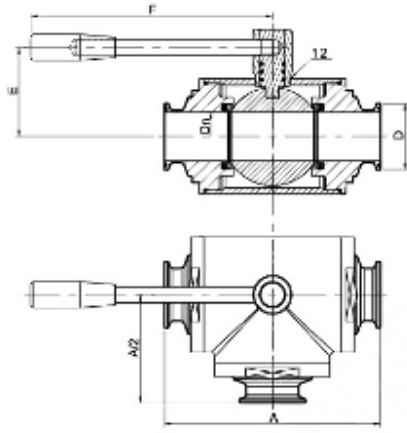

No.20270 Three-way ball valve(DIN)

SIZE	Dn	D	A	E	F
DN25	25	50.5	140	50	146
DN32	31	50.5	156	64	185
DN40	37	50.5	172	68	185
DN50	49	64	182	95	243
DN65	66	91	196	104	243
DN80	81	106	256	122	273
DN100	100	119	286	173	273

No.20271 Three-way ball valve (3A SMS ISO IDF BS)

SIZE	Dn	D	A	E	F
1"	22.4	50.5	140	64	185
1 _{1/2} "	28.8	50.5	156	64	185
1 _{3/4} "	35.1	50.5	165	68	185
2"	47.8	64	182	73	205
2 _{1/2} "	59.5	77.5	196	95	243
3"	72.2	91	225	104	243
4"	97.6	119	286	173	273

